

# HDP 250 L High Pressure Pump series

## Design criteria

Hammelmann high pressure pumps are built to operate at the continuous maximum duty stated in the performance parameters. Just compare the crankshaft speed, average plunger speed, plunger diameter and power rating.

## Features

- Power ratings up to 250 kW
- Horizontal 5 cylinder design
- Wide variety of complementary ancillaries

## Quality and reliability

- Stainless steel pump head free of alternating stress
- Cross head piston bellows seal
- Choice of application specific seal assemblies
- Solid ceramic or tungsten carbide plungers
- Choice of bronze or stainless steel suction chamber
- Crank section calculation by 'Finite element method' ensures long working life under continuous load
- Crankshaft supported by 3 bearings and incorporating twin helical speed reducing gears
- Pressurised oil lubrication system with oil cooler/filter

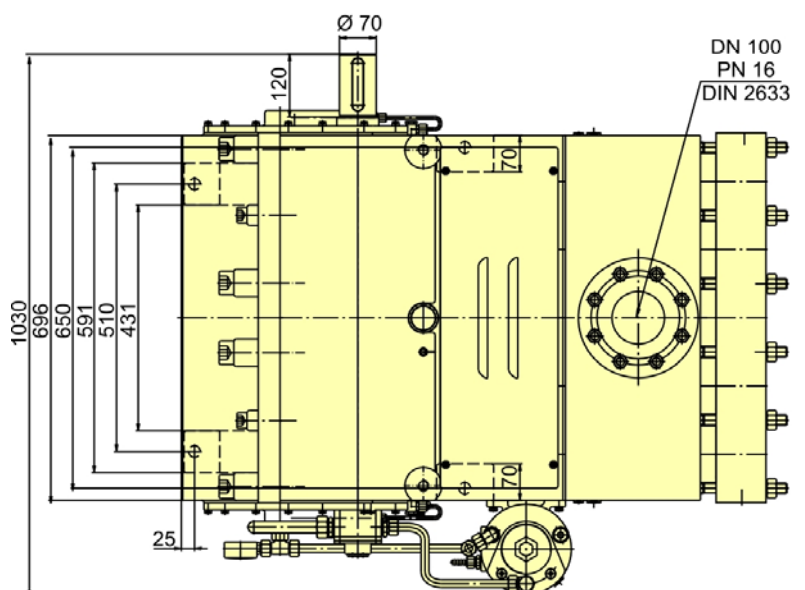
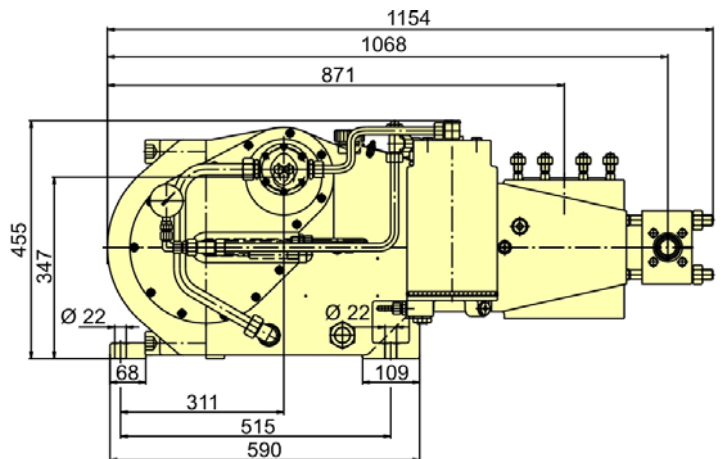
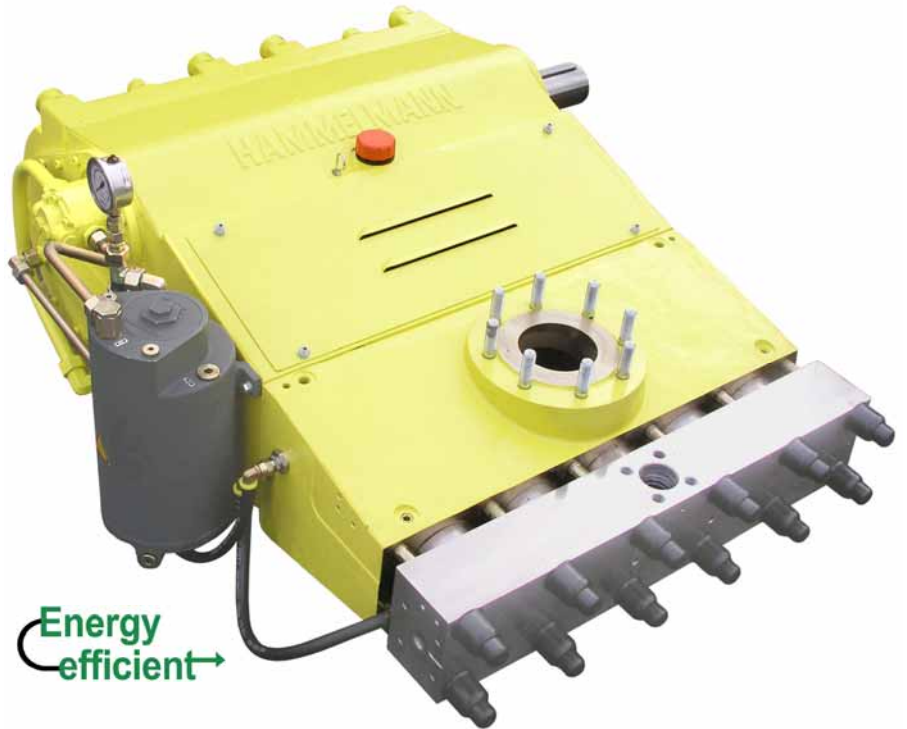

**High pressure pump**  
Weight: approx. 1050 kg

# Technical data, series HDP 250 L

## Performance parameters

Q [l/min]*	Required power rating [kW]					D	r.p.m.	
	110	132	160	200	250		n 1	n 2
Operating pressure [bar]								
32	1800	2250	2750	3000		17,5	1500	390
38	1500	1800	2250	2850	3000		1500/1800	465
46	1250	1500	1800	2350	3000		1800/2150	555
42	1350	1650	2100	2600		20	1500	390
50	1150	1350	1650	2150	2600		1500/1800	465
60			1350	1700	2250		1800/2150	555
* At pressures over 2000 bar approx. 5% of the flow rate is lost due to the compressibility factor of water								
67			1250	1600	1650	25	1500	390
80				1300	1650		1500/1800	465
96					1350		1800/2150	555
97	610	730	890	1100	1160	30	1500	390
116	510	610	740	920	1150		1500/1800	465
139	420	510	620	770	960		1800/2150	555
132	450	540	650	810	850	35	1500	390
158	370	450	540	680	850		1500/1800	465
189	310	370	450	560	710		1800/2150	555
174	340	410	500	620	650	40	1500	390
208	280	340	410	520	650		1500/1800	465
249	240	280	340	430	540		1800/2150	555
222	270	320	390	490	510	45	1500	390
266	220	270	330	410	510		1500/1800	465
319	190	220	270	340	430		1800/2150	555
277	220	260	320	400	420	50	1500	390
332	180	220	260	330	410		1500/1800	465
398	150	180	220	270	340		1800/2150	555
339	180	210	260	330	340	55	1500	390
406	150	180	220	270	340		1500/1800	465
486	120	150	180	230	280		1800/2150	555
395	150	180	220	270	290	60	1500	390
473	120	150	180	230	280		1500/1800	465
567	100	120	150	190	240		1800/2150	555
538	110	130	160	200	210	70	1500	390
644	90	110	130	170	210		1500/1800	465
766	70	90	110	140	170		1800/2150	555

- Rod force: 82 kN
- Stroke: 75 mm
- Mean piston speed at n<sub>2</sub>
  - 390 r.p.m. = 0,97 m/sec
  - 465 r.p.m. = 1,16 m/sec
  - 555 r.p.m. = 1,39 m/sec

D = Piston/Plunger dia. [mm]  
n1 = Motor/Engine r.p.m.  
n2 = Crankshaft

### Conversion table

Rating 1 kW = 1,34 HP  
Op. Pressure 1 bar = 14,5 psi  
Flow rate 1 l = 0,264 US gallon  
1 l = 0,22 Imp. gallon



Hammelmann plunger pumps convert 93 to 98 % of the shaft power to hydraulic energy.

**Hammelmann**  
Maschinenfabrik GmbH  
Postfach 3309 • D-59282 Oelde Telefon (0 25 22) 76-0  
Zum Sundern 13-21 • Germany Telefax (0 25 22) 76-444  
eMail: mail@hammelmann.de • Internet: www.hammelmann.de

**HAMMELMANN®**